

**Document ID# 1663262
2005 Cadillac CTS**

**3.6L LY7 with Cam Actuator DTC - keywords
camshaft crankshaft MIL reluctor SES P0008
P0009 P0016 P0017 P0018 P0019 #PIP3423 - (May
24, 2005)**

3.6 LY7 with Cam Actuator DTC

2005 Buick LaCrosse

2004-2005 Buick Rendezvous

2004-2005 Cadillac CTS, SRX

2005 Cadillac STS

The following diagnosis might be helpful if the vehicle exhibits the symptom(s) described in this PI.

Condition/Concern:

Vehicles with 3.6 LY7 may exhibit DTC P0016, P0017, P0018, P0019, P0008 or P0009.

Recommendation/Instructions:

The reluctor for the crankshaft sensor pressed on the crankshaft may have moved. Refer to attached photographs for exact location.

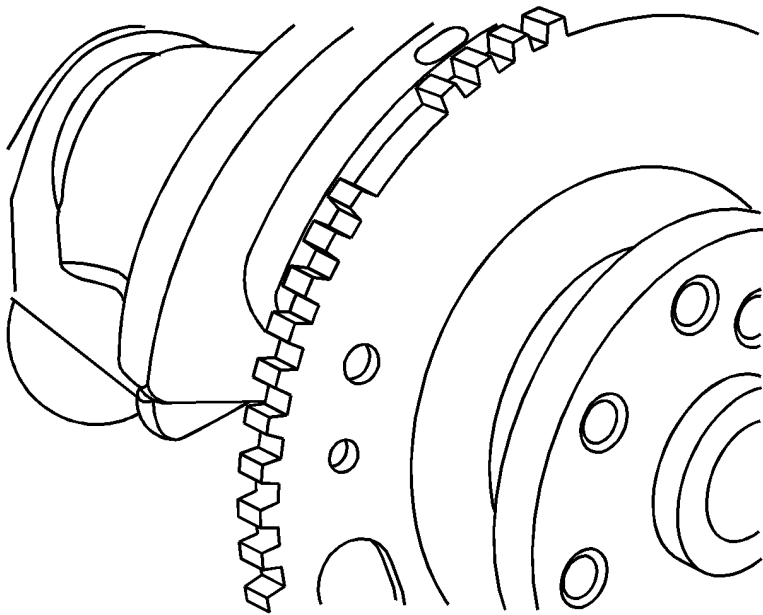
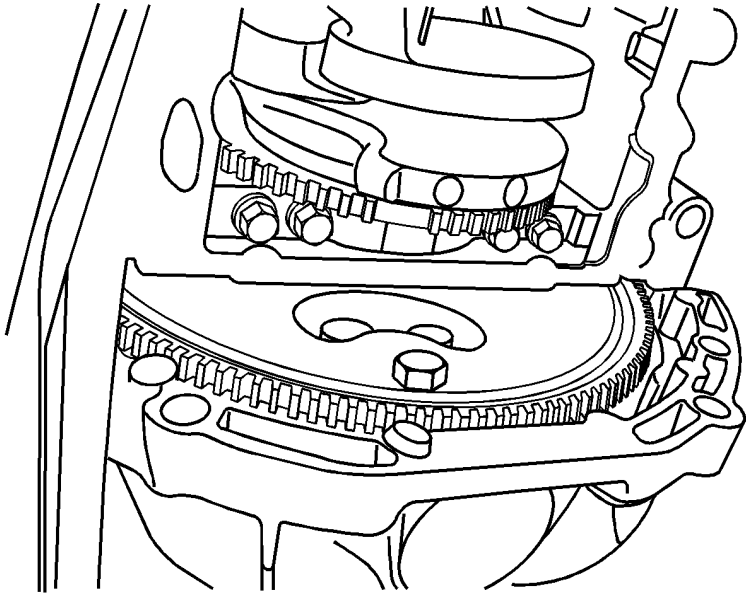

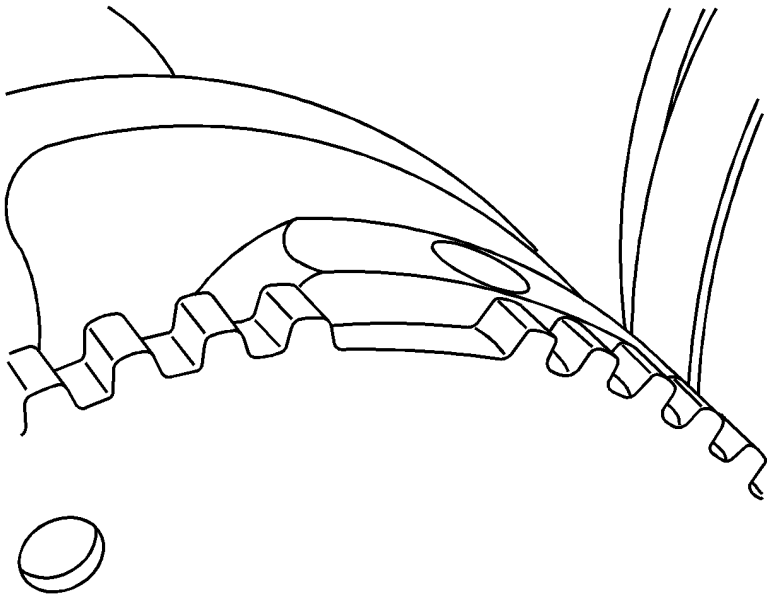
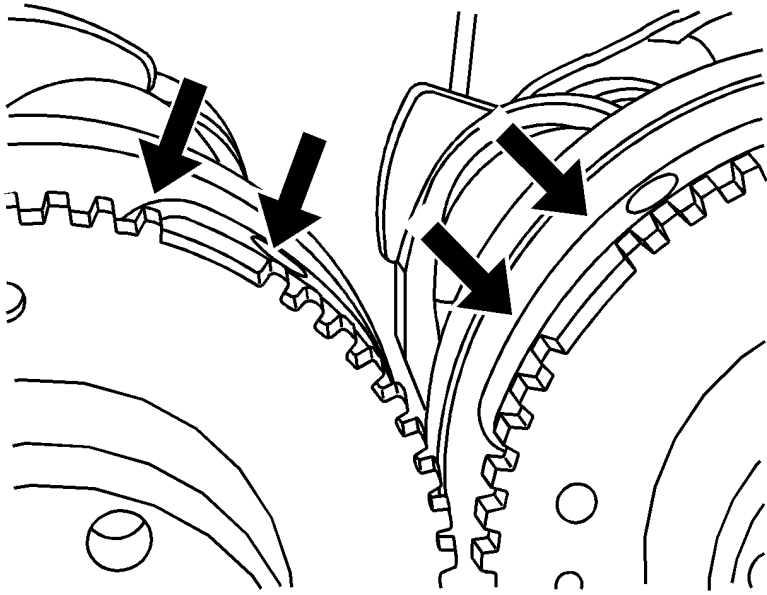

Please follow this diagnosis process thoroughly and complete each step. If the condition exhibited is resolved without completing every step, the remaining steps do not need to be performed.

GM bulletins are intended for use by professional technicians, NOT a "do-it-yourselfer". They are written to inform these technicians of conditions that may occur on some vehicles, or to provide information that could assist in the proper service of a vehicle. Properly trained technicians have the equipment, tools, safety instructions, and know-how to do a job properly and safely. If a condition is described, DO NOT assume that the bulletin applies to your vehicle, or that your vehicle will have that condition. See your GM dealer for information on whether your vehicle may benefit from the information.



**WE SUPPORT
VOLUNTARY
TECHNICIAN
CERTIFICATION**

© Copyright General Motors Corporation. All Rights Reserved.

**Document ID# 1663262
2005 Cadillac CTS**