



Installation Instructions for:
INTERCOOLED SUPERCHARGER SYSTEM
2004-2005 CADILLAC CTS-V



Step-by-step instructions for installing the best in
supercharger systems.

Magnuson Products Inc
3172 Bunsen Ave, Ventura, CA. 93003
(805) 642-8833 * (805) 677-4897 fax
magnusonproducts.com * magnacharger.com



INSTALLATION MANUAL
Magna Charger
GM 5.7 Liter Engine,
2004-2005 Cadillac CTS-V

Please take a few moments to review this manual thoroughly before you begin work:
Make quick parts check to make certain your kit is complete (See shipper parts list in this package). If you discover shipping damage or shortage, please call our office immediately.
Take a look at exactly what you are going to need in terms of tools, time, and experience.
Review our limited warranty with care.

When unpacking the supercharger kit **DO NOT** lift the supercharger assembly by the black plastic bypass actuator. This is pre-set from the factory and can be altered if used as a lifting point!

Caution: Relieve the fuel system pressure before servicing fuel system components in order to reduce the risk of fire and personal injury. After relieving the system pressure, a small amount of fuel may be released when servicing the fuel lines or connections. In order to reduce the risk of personal injury, cover the regulator and fuel line fittings with a shop towel before disconnecting. This will catch any fuel that may leak out. Place the towel in an approved container when the job is complete.

Use only premium fuel, 91 octane or better.

Magna Charger systems are manufactured to produce about 20 RWHP per pound of boost at sea level. High altitudes will produce different numbers.

Our Magna Charger kits are designed for engines in good mechanical condition only. Installation on high mileage or damaged engines is not recommended and may result in engine failure, for which we are not responsible. Magna Charger is not responsible for the engine or consequential damages.

Aftermarket engine recalibration devices that modify fuel and spark curve (including, but not limited to programmers) are not recommended and may cause engine damage or failure. Use of non-Magna Charger approved programming will void all warranties. If you have any questions, call us.

After you finish your installation and road test your vehicle, please fill out and mail in the limited warranty card, so we can add you to our files (this is important for your protection).

A new GM fuel filter is recommended at the time of supercharger installation.

Stock spark plugs and stock plug gap is recommended

Drive belt= Gates# K061010

Air Filter= K&N# 33-2289

Tools Required:

- Metric wrench set
- 1/4" - 3/8" and 1/2" drive metric socket set (Standard & Deep)
- 3/8" and 1/2" drive Foot pound and inch pound torque wrenches
- Phillips and flat head screwdrivers
- Fuel line quick disconnect tools (included in kit)
- Small or angled 3/8 drill motor
- Drain pan
- Hose cutters
- Hose clamp pliers
- Safety glasses
- Metric Allen socket set 3/8 drive
- Shop vacuum cleaner

Contact information:

Magnuson Products Inc
Magna Charger Division
3172 Bunsen Ave.
Ventura, CA 93003
Sales/Tech support 805-289-0044
Websites:
www.magnusonproducts.com
www.magnacharger.com
Email:
info@magnacharger.com

1. Start the supercharger installation by removing the lower rear seat cushion by pushing in at the base and then pulling up. Remove the cushion to gain access to the two rear fuse centers located where the carpet meet the seat base.



2. Once the seat cushion has been removed pull back the carpet where it meets the seat base on the left (driver) side to expose the fuse center. Remove the fuse center cover and examine the legend printed inside the cover to locate the fuse marked “Audio”. Remove the 10 amp “Audio” fuse so the vehicles PCM (engine management computer) can be re-programmed safely. **THIS FUSE MUST BE REMOVED BEFORE REPROGRAMMING!**

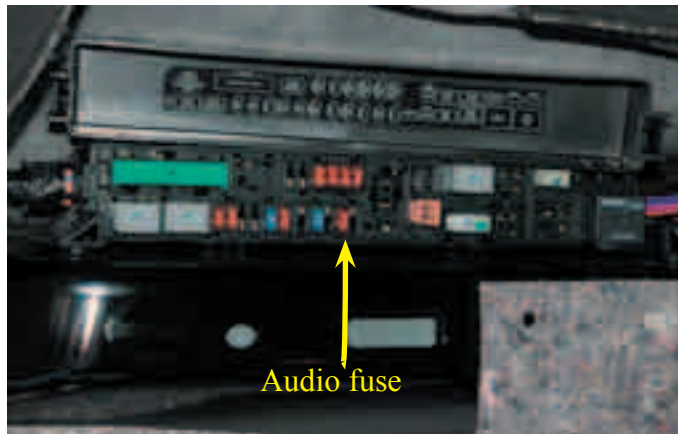

3. Pull back the carpet where it meets the seat base on the right (passenger) side to expose the other fuse CENTER. Remove the fuse center cover and examine the legend printed inside the cover to locate the fuse marked “Fuel Pump Mtr”.

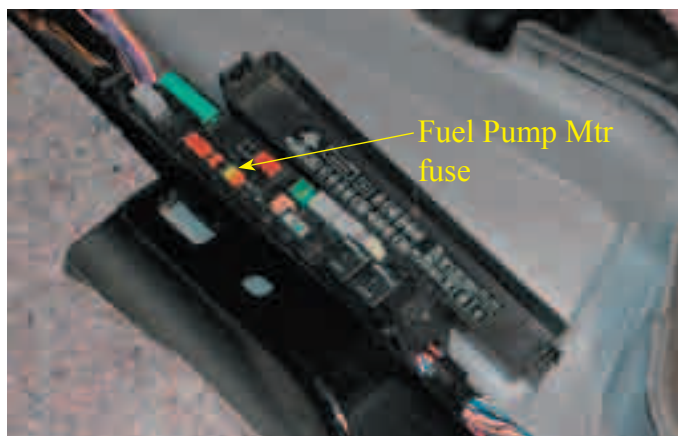

4. Remove the stock “Fuel Pump Mtr” fuse and replace it with the 30 amp fuse supplied. Replace the fuse center cover.

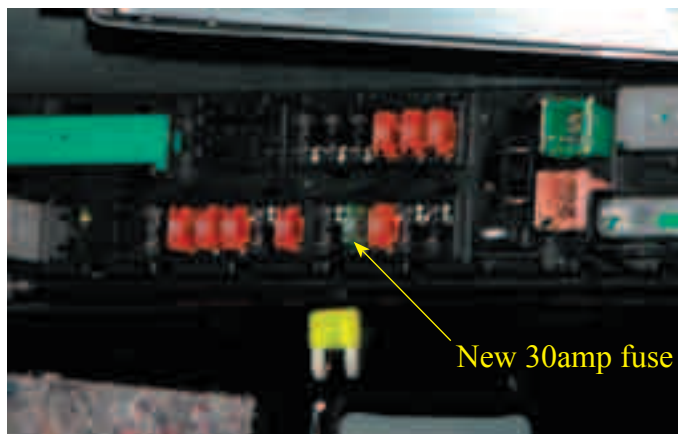

5. Locate the OBD II plug connection along the bottom edge of the dash to the right of the hood release lever.

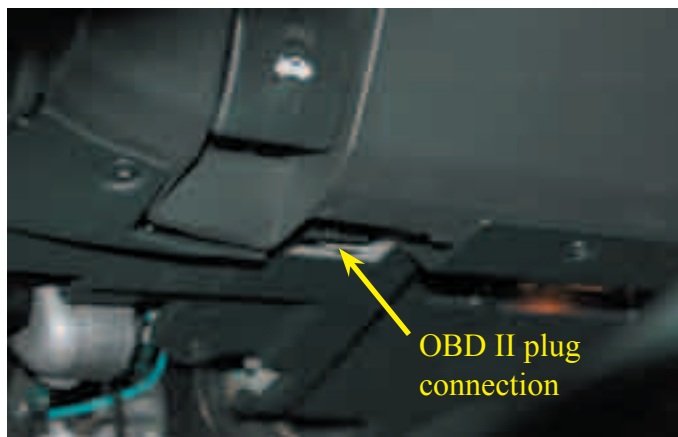

6. Connect the cable supplied with the microtuner to the 9-pin connector at the top of the handheld unit. Use the thumbscrews to secure the cable to connector. Connect the other end to your OBD II plug connection. Make sure this connection is seated all the way in and that it is secure. This connection must remain secure during programming. NOTE: It is very important that the instructions for the programmer are carefully read and understood. All steps should be followed exactly. If you have any questions, contact Superchips or Magnuson Products Inc immediately.



7. Turn the ignition key to the on or run position but do not start the vehicle. To begin programming your vehicle, you must press the YES button. Press the YES button once to start the programming cycle. The programming process takes about five minutes. The handheld unit will inform you that the programming process has completed and to turn the ignition off and disconnect the cable. Only at this time should the ignition be turned off and the cable removed



8. *DO NOT DISTURB THE CABLE OR TURN THE IGNITION OFF DURING THIS TIME! IF THE PROGRAMMING IS DISRUPTED YOUR COMPUTER WILL NOT START OR RUN YOUR VEHICLE! If you should get the message "ERROR NO VIN STORED OR THIS MODEL YEAR NOT SUPPORTED" on the Microtuner display, remove the cable and Microtuner from the OBD II port and take your vehicle back to your Cadillac dealer and ask to have your PCM program updated to the current program.



9. Replace the “Audio” fuse and the fuse center cover. Replace the lower rear seat cushion by pushing in at the base and then pushing down. Take care to ensure the seatbelt buckles are placed in the slots provided for them in the back edge of the seat cushion.



10. Remove the **Negative** battery connector from the battery. Snap the black plastic terminal off the connector and then remove the battery connector with a 8mm wrench. Position the connector away from the battery so that it won't make accidental contact during the supercharger installation.



11. Squeeze and pull to remove the two caps that cover the wiper arm attachment nuts



12. Remove the wiper arm attachment nuts with a 15mm socket wrench.



13. Note the position of the wiper arms on the windshield and then pull up firmly to remove the wiper arms.



14. Remove the rubber weather strip from the front edge of the wiper arm apron.



15. Remove the four 7mm bolts that secure the wiper apron on the right (passenger) side.

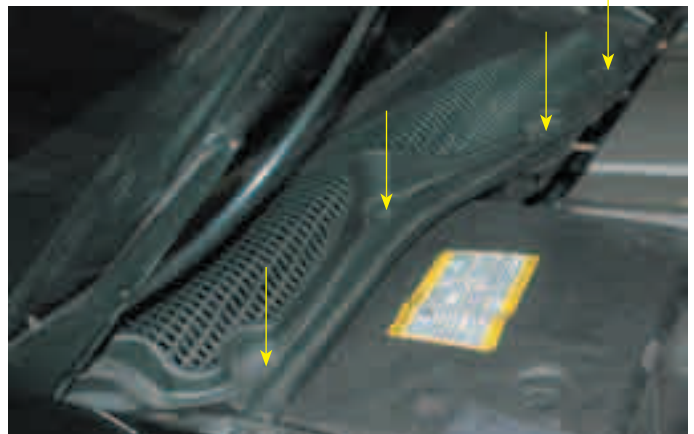

16. In the corner of the left (driver) side wiper apron, remove the bolt that secures it with a 10mm socket wrench.



17. Pull the right wiper apron forward at the center, then remove the left apron completely.



18. Located on the bottom of the wiper assembly is the wiper motor electrical connector. Disconnect the connector from the motor.



19. Remove the wiper assembly retaining bolt near the center of the windshield with a 13mm socket wrench.



20. Remove the wiper assembly complete from the vehicle



21. From the top surface of the left wiper arm lever, measure down 3/8”(10mm) and scribe a line across the lever. Using a suitable grinder or saw remove all the material above this line.

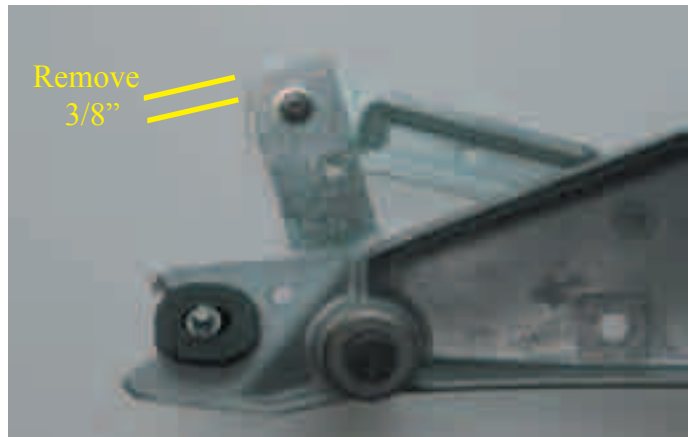

22. Install the thick spacer washer supplied over the wiper assembly mounting hole.



23. Re-install the wiper assembly into place. Note that the mounting bolt will pass through the spacer washer installed in the previous step.



24. Tighten the mounting bolt securely and re-attach the electrical connector on the bottom of the wiper motor.



25. Replace the wiper aprons, mounting screws and weather strip into their original locations.



26. Replace the wiper arms into their original positions on the spindle shafts and torque the attachment nuts to 26 ft-lbs.



27. On the top of the strut towers remove the two bolts on each side that secure the strut tower brace with a 18mm socket wrench.



28. Remove the strut tower completely, as it cannot be reused with the supercharger. Replace the bolts into their original holes and torque them to 83 ft-lbs. While the strut tower brace is not completely necessary, a replacement to fit around the supercharger system is available from Lund Cadillac Performance Division Inc. Contact them at 1-602-375-4383



29. Pull up firmly at the front and back of the engine cover to remove it. It will not be reused.



30. Remove the radiator mask by removing the two push rivets out along the front edge. Pull up firmly along the back edge to unclip the mask for removal.



31. To remove the push rivets, use a small straight blade screwdriver to pry up the center of the rivet and then the outer body.

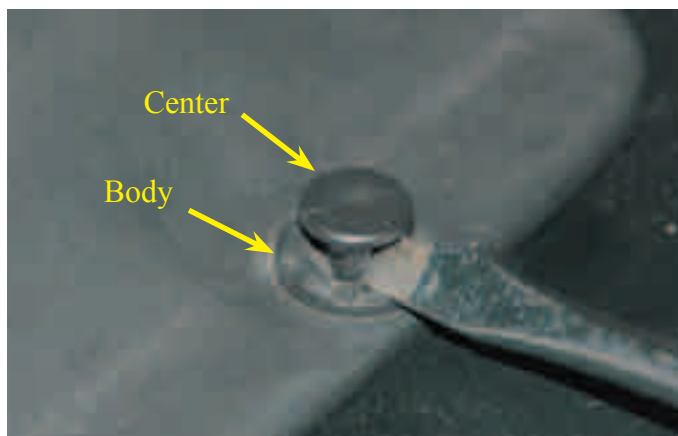

32. Raise the front of the vehicle on jackstands or a lift and remove the lower front splash panel from the bottom of the vehicle. Remove the panel by removing the 13 push rivets in the areas shown.

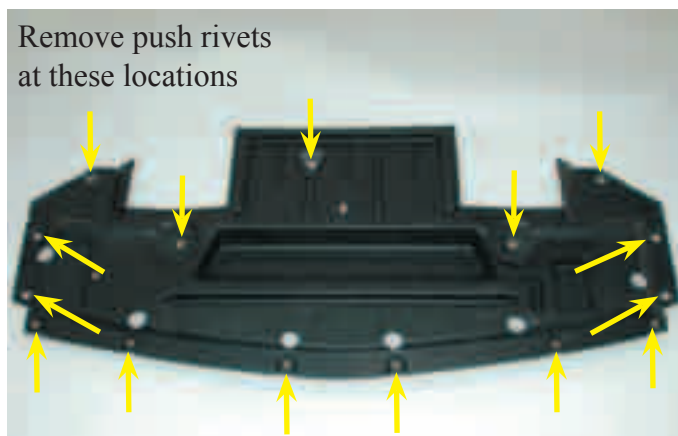

33. Remove the eight push rivets that secure the top edge of the front fascia as shown.

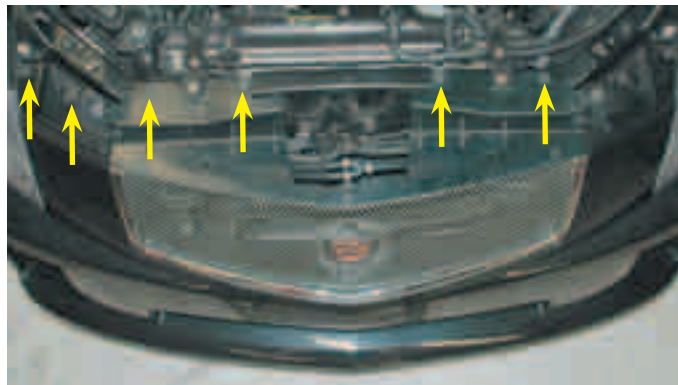

34. Along the front edge of both front wheel wells remove the push rivets as shown.



35. Rotate the steering wheel to full lock so you can push the wheel well splash panel out of the way to gain access to the two fascia lock bolts on each side. As you loosen the the nuts on the lock bolts the fascia panel will drop down forming a gap between the fascia and the fender. It is not necessary to remove the lock bolt nuts or the lock bolts themselves.

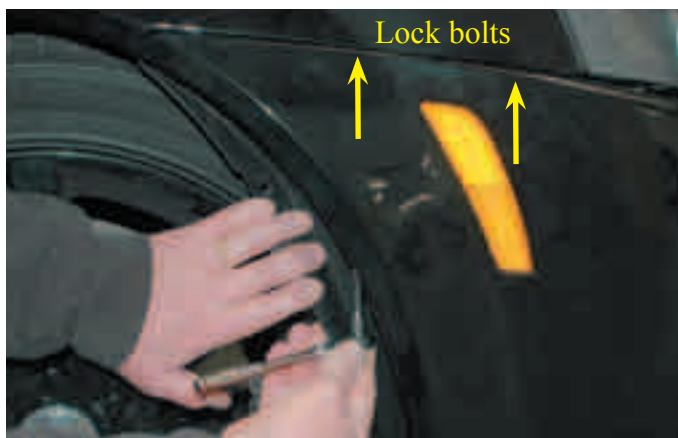

36. The lock bolts are located before and after the marker lamp, where the fascia panel meets the fender as shown in this photo from the inside of the fascia.



37. After loosening the lock bolts, pull forward on the fascia panel. The lock bolts will slide forward in their “keyhole” shaped holes and allow the fascia to detach from the vehicle.

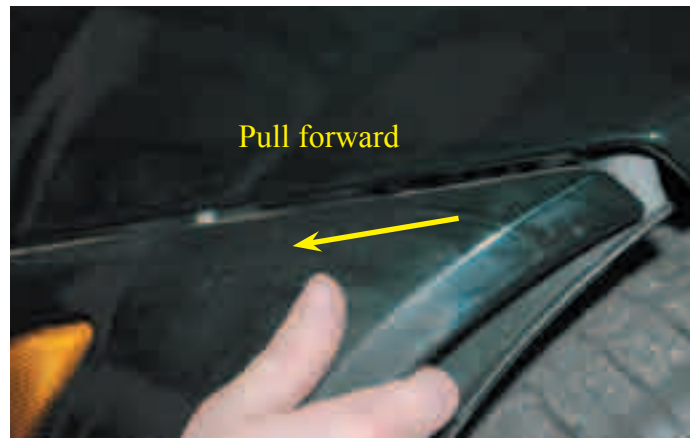

38. On both sides of the fascia disconnect the marker light electrical connection.



39. On both sides of the fascia disconnect the turn signal /driving light electrical connection. Remove the fascia carefully from the vehicle and set it aside.



40. Remove the air tube by loosening the clamps with a 8mm nut driver at the throttle body and Mass Air Flow meter (MAF).



41. Remove the air tube completely, as it will not be reused.



42. On the left (left) side of the throttle body, disconnect the Electronic Throttle Control (ETC) connector.



43. Disconnect the Throttle Position Sensor (TPS) connector on the right (passenger) side of the throttle body.



44. Disconnect the eight injector electrical connectors.

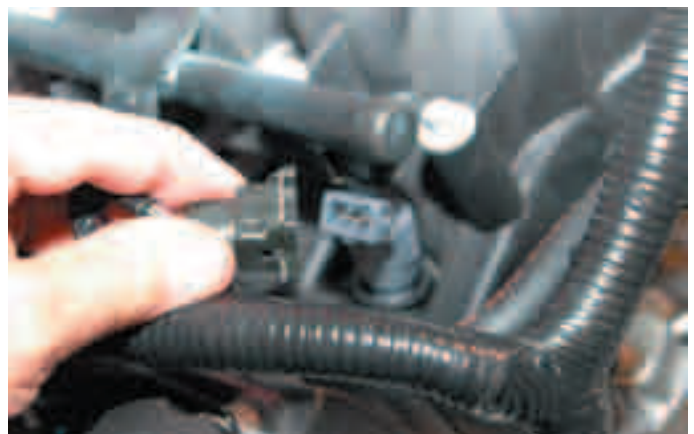

45. Disconnect the two ignition coil pack connectors.

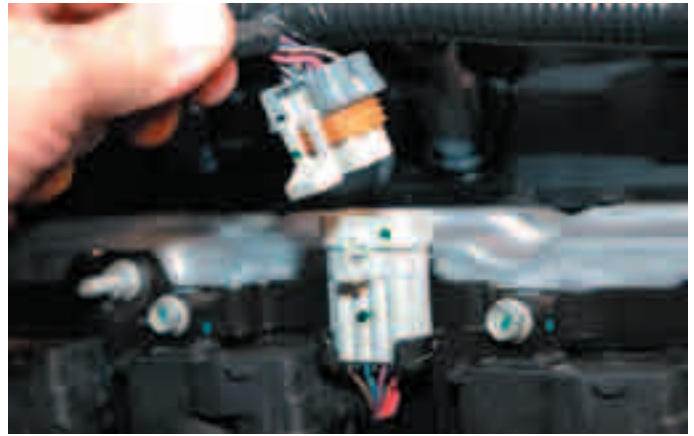

46. Unclip the Engine Knock Sensor (Knock) connector from its location on the back of the intake manifold. Next disconnect the Knock connector from the wiring harness connector.



47. Disconnect the Manifold Absolute Pressure sensor connector at the rear of the intake manifold.



48. Disconnect the Positive Crankcase Ventilation (PVC) hose from the right side of the throttle body.



49. Disconnect the engine valley cover vent hose from the nipple in the intake manifold.



50. Disconnect the vacuum brake booster valve from its mounting grommet on the booster.



51. Above the driver side (right) valve cover, disconnect the Evaporative Purge Solenoid (EVAP) electrical connector.



52. Press the white release trigger on the Evaporative emission (Evap) pipe connector to remove it from the barb on the intake manifold. Disconnect the other end of the Evap pipe from the purge solenoid.



53. Disconnect the Evap pipe from the rear of the purge solenoid. Follow the Evap pipe to the right rear of the engine and unclip it from the fuel rail. Disconnect the Evap pipe from the smaller quick-release fitting using the supplied removal tool. Snap the tool on the pipe and push it into the quick release fitting to release the pipe.



54. Remove the Purge solenoid and EVAP line by pulling the solenoid free from its mounting location on the left side of the intake manifold.



55. On the left side of the intake manifold, locate the fuel pressure test port at the front of the fuel rail and remove the cap. CAUTION! The fuel in the system is under pressure! Relieve the pressure in the system by depressing the check valve with a screwdriver and collecting the fuel with a shop towel.



56. Remove the retaining clip from the fuel line quick-release connection.



57. Disconnect the fuel pipe from the large quick-release fitting using the supplied removal tool. Snap the tool on the pipe and push it into the quick release fitting to release the pipe.



58. Remove the two coolant lines attached to the bottom of the throttle body.

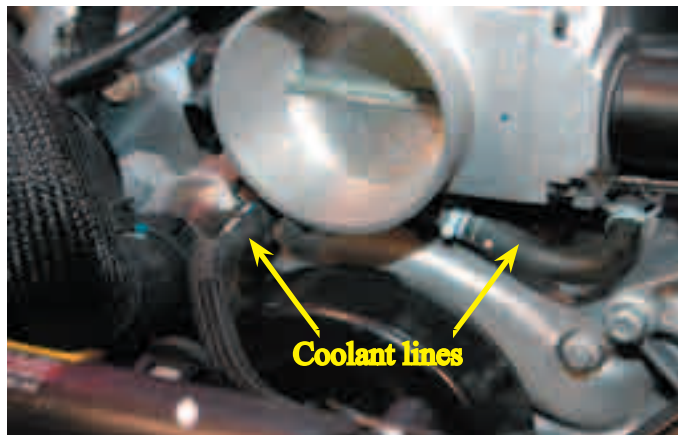

59. Remove the three bolts attaching the throttle body to the intake manifold with a 10mm socket wrench. Set the throttle body and bolts aside for later installation on the supercharger assembly.



60. Remove the three bolts attaching the throttle body to the intake manifold with a 10mm socket wrench. Set the throttle body and bolts aside for later installation on the supercharger.

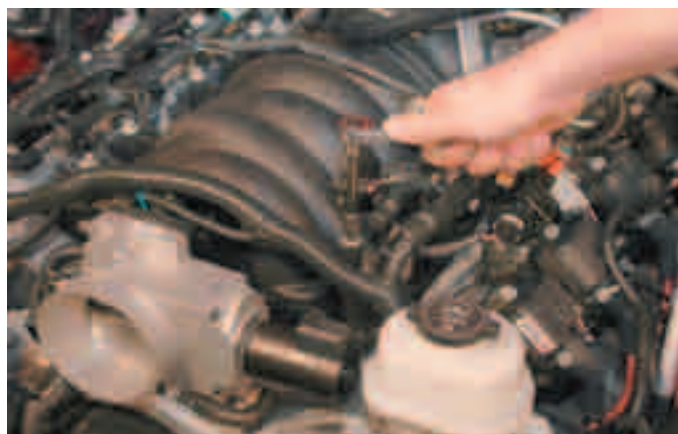

61. Remove the ten intake manifold bolts with a 8mm socket wrench. Note you may not be able to completely withdrawal all ten bolts from the manifold after unthreading them.



62. Using a shop vacuum cleaner, remove any dirt or debris from the intake port and engine valley cover area.



63. Cover the intake ports with tape or clean rags



64. On the engine valley cover, remove the two black rubber Knock Sensor covers by gently prying them up using a small straight blade screwdriver. Disconnect the electrical connectors by squeezing the sides of the connectors with a pair of long jaw or needle nose pliers and pulling them up.

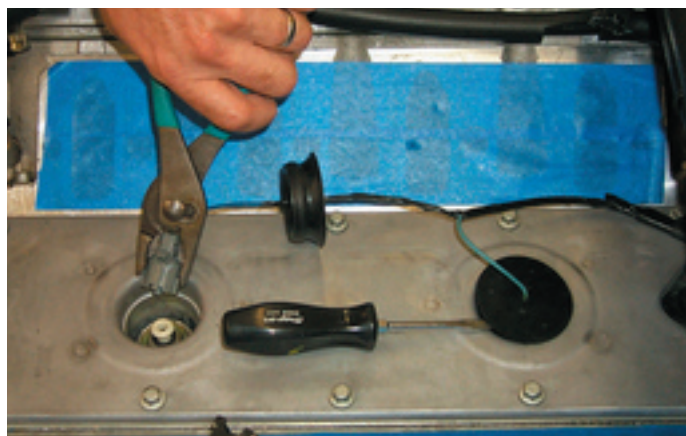

65. Remove the Knock sensors by using a ratchet and a deep 22mm socket.

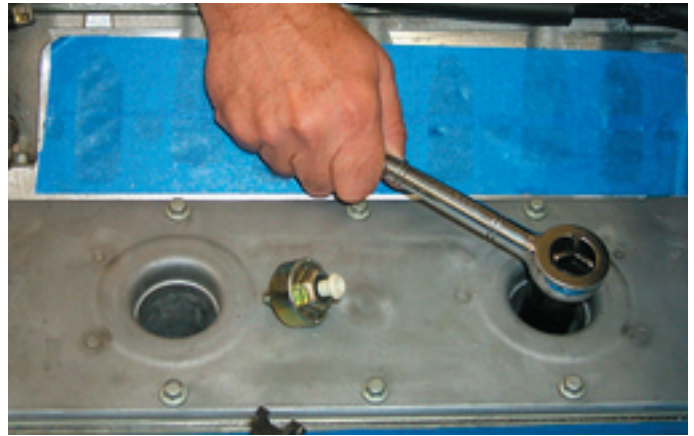

66. Remove the engine valley cover and gasket by removing the ten bolts with a 10mm socket wrench.



67. Remove the accessory serpentine belt by rotating the tensioner bolt with a 15mm wrench. Release the slack and then pull the belt off the tensioner pulley.

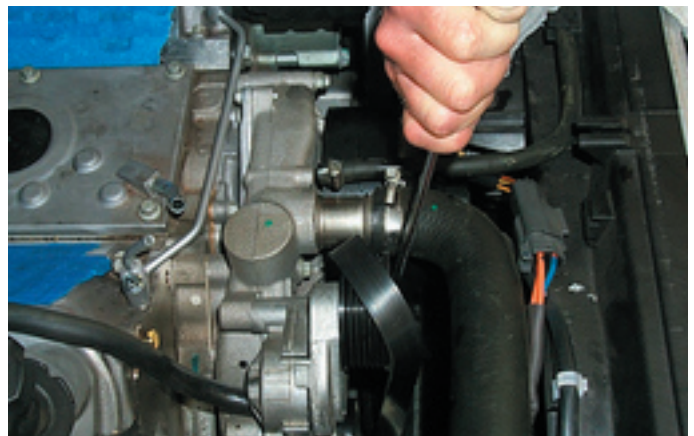

68. The gasket will be reused, the original valley cover will not. Inspect the gasket for any damage and then re-install, note that it will only fit correctly in one position.

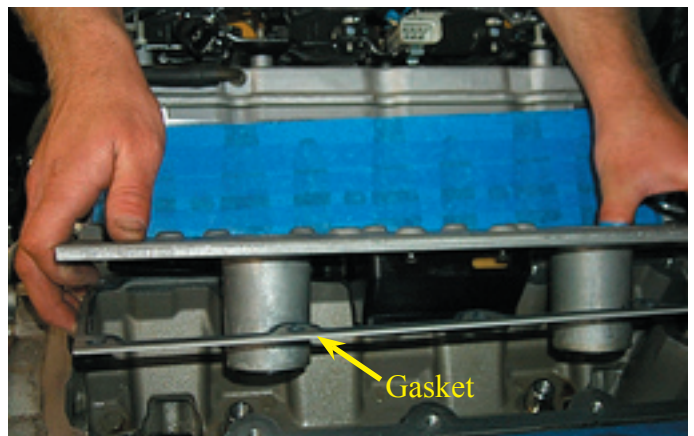

69. Install the new valley cover and ten flathead bolts supplied with a 5mm Allen socket. Torque the bolts to 18ft-lb.



70. Reinstall the knock sensors and torque them to 15 ft-lb. Re-attach the electrical connectors by pushing the connector down firmly until a “click” is heard. Before reinstalling the covers, apply a bead of silicone adhesive to the sides of each cover then push the covers back into place.



71. Remove the tape from the knock sensor wires so that they can be installed in the grooves in the top of the valley cover. Use some tape to hold the wires in place temporarily, and then use silicone adhesive to retain the wires permanently. Insert the six O-rings supplied in the recesses in the new valley cover.

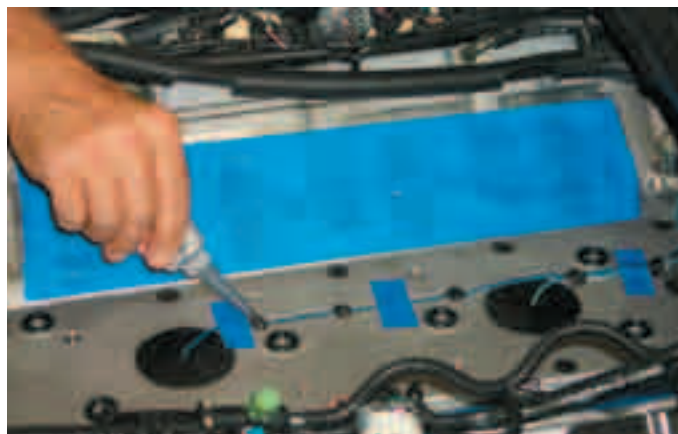

72. Remove the two coolant vent pipe bolts with a 10mm socket wrench.



73. Remove the coolant vent pipe. Ensure that the O-ring gaskets under the vent pipe blocks do not stick to the cylinder heads. If so, remove them as new gaskets are supplied.



74. Install the new coolant vent pipe with the supplied gaskets and bolts. Torque the bolts to 106 in-lbs with a torque wrench and 10mm socket.



75. Remove the stock belt tensioner assembly by removing the two mounting bolts with a 15mm socket wrench.



76. Install the new tensioner assembly in place of the stock unit with the supplied bolts and torque them to 40 ft-lbs.



77. Remove the radiator retaining bracket on each side by removing the four bolts with a 10mm socket wrench



78. Remove the Air conditioning (A/C) condenser from the radiator by removing the four bolts along the top and bottom radiator tanks with a 10mm socket wrench.



79. Squeeze the hose clamps with a pair of pliers and remove the upper and lower radiator hose connections.



80. Disconnect the radiator vent hose from the top tank by squeezing the hose clamp with a pair of pliers and pulling the hose off.



81. On the left side of the engine, remove the A/C pipe support tab from the fan shroud with a right angle cross-head screwdriver.



82. Disconnect the radiator fan electrical connections on each fan by squeezing the connectors and pulling them free.



83. Remove the radiator, fan and hoses complete by pulling it straight up and out carefully.



84. Due to the extra power generated by the supercharger system it is necessary to give the harmonic balancer additional support in its location on the end of the crankshaft. This is achieved by “pinning” the balancer to the crankshaft with two hardened steel dowel pins. These are the supplied parts and tools necessary to do this.



85. Remove the stock balancer bolt from the end of the crankshaft with an impact gun and a 24mm socket.



86. Install the drill guide and bolt into the stock location. Note that the smaller diameter end of the guide goes towards the balancer.



87. Torque the guide bolt to 60 ft-lbs with a torque wrench and 24mm socket.



88. Using a drill and the supplied drill bit, drill **Two** holes in the balancer by placing the drill bit in the two holes in the guide. Take your time, as the material will cut slowly. Note that the drill bit has a “shoulder” on it. Continue drilling until the shoulder of the drill bit contacts the drill guide.



89. A light lubricant will help the drilling and reaming process. Drill the holes in several steps lubricating the hole and bit between each step.



90. After drilling the two holes, use the supplied reamer to correctly size the holes. Rotate the reamer **clockwise** only. Turning it the other direction will ruin it.



91. Use some compressed air to remove any material from the holes.



92. Remove the drill guide and bolt from the end of the crankshaft.



93. Inspect the two new holes carefully and use more compressed air to remove any residual material. Install a dowel pin into each hole.



94. Use a small hammer and a drift to tap the dowel pins in as far as they will go into the balancer.



95. Install the new balancer bolt supplied.



96. Use a torque wrench and 24mm socket to tighten the new balancer bolt to 37 ft-lbs and then rotate it an additional 140 degrees using a torque angle meter. The radiator and hoses will be replaced in a later step.



97. Locate the MAF connector and remove the tape from the wires. Approximately 3” back from the connector, cut the two **Brown** Inlet Air Temperature wires.



98. Using the new IAT harness, lengths of white wire and crimps connectors supplied, Install the IAT connector and extension wires to the two ends of the brown wires leading to the computer. It does not matter which white wire connects to either brown wire. The two wires from the MAF connector will no longer be used.

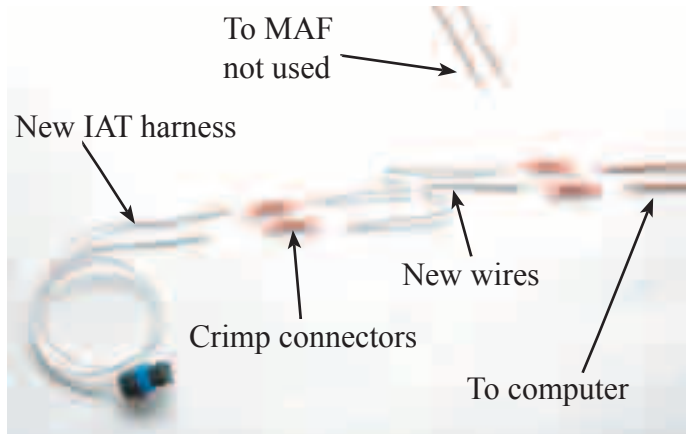

99. Strip about 1/4” of insulation from the ends of all the wires, then crimp the connectors on. Using a heat gun or blow dryer set on “High” shrink the insulation on the crimp connectors so that it contracts around the wires completely. **You must shrink the insulation, as crimping the connections alone is not enough to secure them!**



100. Cover the new IAT harness with the split loom supplied.



101. Locate the purge solenoid connector and remove the plastic tape. Cut the wires approximately 4" back from the connector.

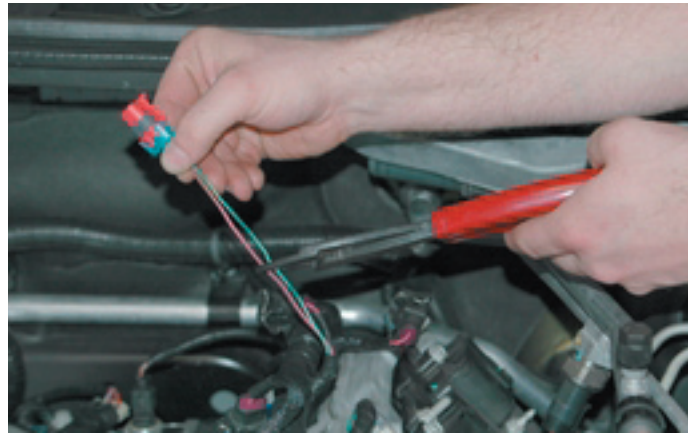

102. Using the new lengths of color coded wire and crimps connectors supplied to extend the purge solenoid connector wires. Strip about 1/4" of insulation from the ends of all the wires, then crimp the connectors on. Using a heat gun or blow dryer set on "High" shrink the insulation on the crimp connectors so that it contracts around the wires completely. You must shrink the insulation, as crimping the connections alone is not enough to secure them!

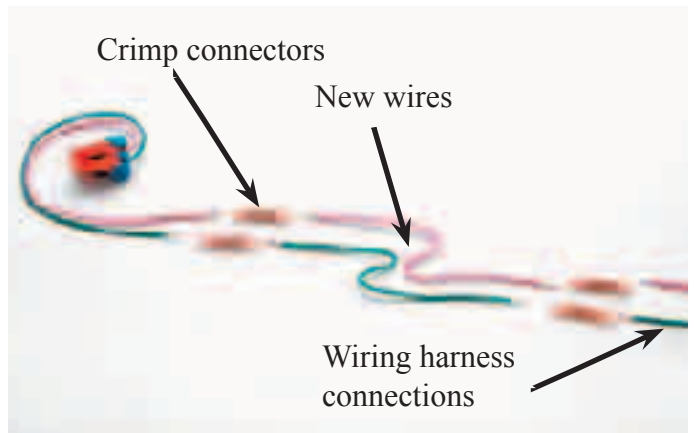

103. Cover the extended wires with the split loom supplied.



104. Place a straight edge across the top surfaces of the throttle body as shown.



105. Scribe a line across the upper tab on the throttle body.



106. Using a small saw or grinder carefully remove the material above the line until the throttle body looks like this.



107. Install the throttle body with the new supplied gasket onto the supercharger inlet manifold using the original three bolts and a 10mm socket wrench.



108. Torque the three throttle body bolts to 89 in-lbs.



109. Assemble the Evap solenoid bracket and bolts onto the fuel manifold.



110. Using some of the lubricant supplied, install the O-ring into the recess in the fuel rail. Install the fuel manifold and bracket on the fuel rail, take care not to pinch the O-ring.



111. Torque the fuel manifold bolts to 106 in-lbs with a torque wrench and 10mm socket.



112. Remove the Manifold Absolute Pressure (MAP) sensor from the stock intake manifold by tilting the sensor forward and lifting it free. Ensure that the orange rubber seal is not missing or damaged as it and the sensor will be re-used.



113. Apply a small amount of the grease supplied to the MAP sensor seal and install the sensor in its new location at the right rear of the supercharger manifold.



114. Install the MAP sensor in its new location using the supplied bracket and the button head Allen screw with a 4mm Allen wrench.

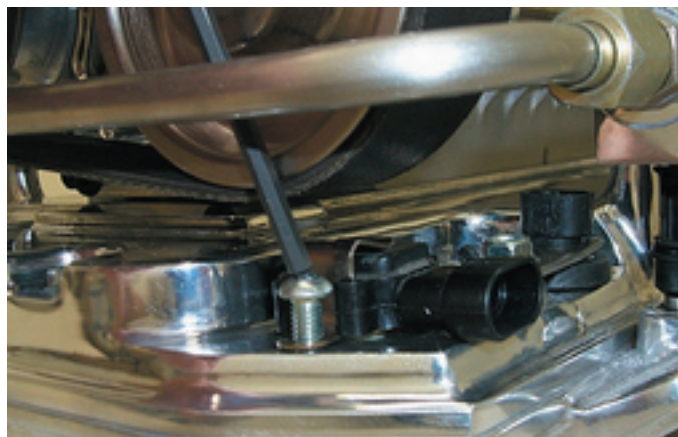

115. Install the eight intake port gaskets into the recesses on the manifold faces. Ensure that the tab on the gasket aligns with the slot on the manifold face. Inspect the manifold ports for any dirt or foreign matter.



116. Remove the tape from the port surfaces and using silicone spray or soapy water apply a light film to allow the port gaskets to slide on the surfaces. Do not use any petroleum based lubricants as these will damage the port gaskets.



117. With the help of a assistant carefully set the supercharger system in place. Take care not to damage the port gaskets.



118. Remove the split-looms that support some of the manifold to cylinder head bolts. Start all ten bolts by hand to ensure proper alignment of the manifold.



119. Using a torque wrench and 10mm socket torque the ten manifold to cylinder head bolts gradually and evenly to 89 in-lbs.



120. At the rear of the supercharger on the passenger side, plug in the MAP and new IAT connections.

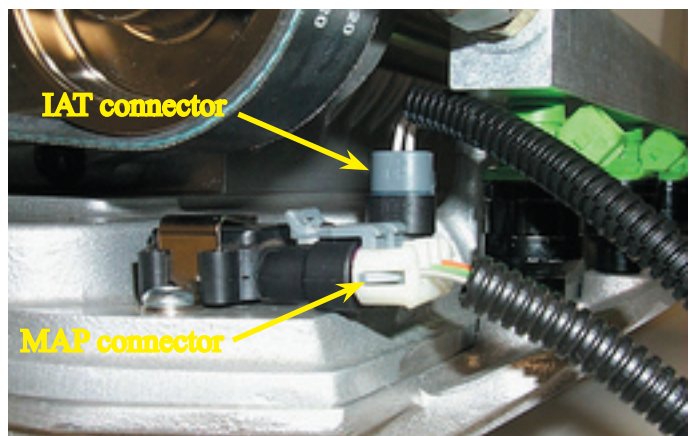

121. At the firewall connect the Knock sensor connector.



122. Install the ignition coil pack connectors on both sides of the engine.



123. Install the connectors on all eight fuel injectors.



124. Install the TPS extension harness onto the harness connector.



125. Install the TPS extension connector onto the throttle body connection.



126. Install the ETC connector onto the throttle body.



127. Install the purge solenoid onto the new bracket and then install the EVAP electrical connector.

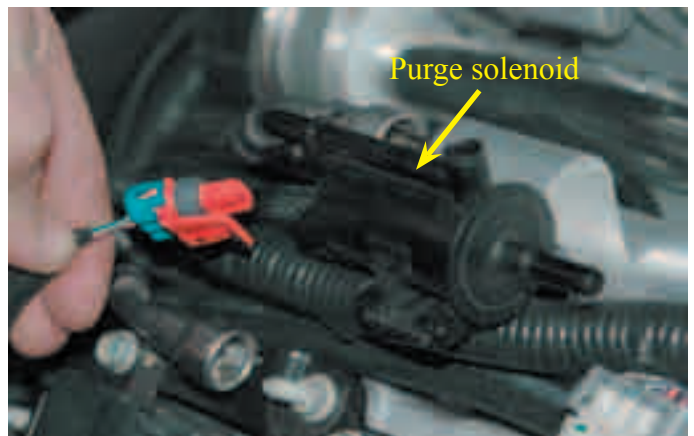

128. Use an adjustable wrench to rotate the PVC barb on the throttle body to the approximate "Four O'clock" position as shown.

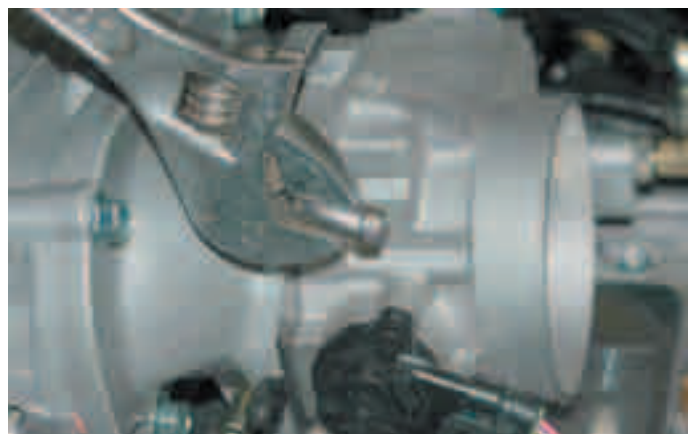

129. Install one end of a 16" length of the supplied 3/8" PCV hose onto the throttle body PCV barb. Install the remaining end of the hose on to the passenger side (right) valve cover PCV barb.



130. At the rear of the driver side valve cover, remove the rubber cap covering the PCV barb.



131. Assemble the new PCV outlet hose by cutting a 43" length and a 2" length of the 3/8" hose. Attach one end of each hose to the 90 degree elbow fitting.

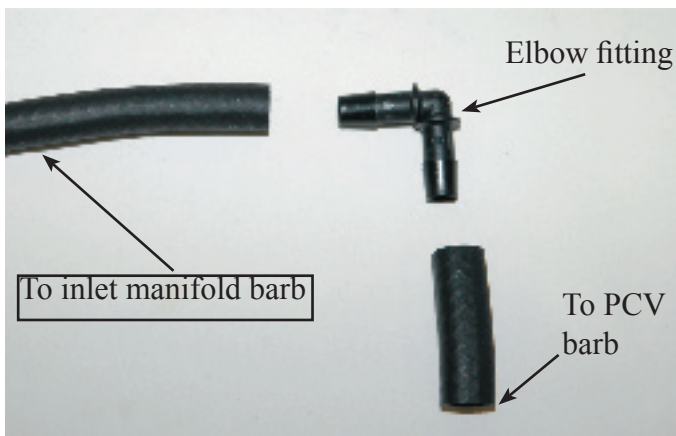

132. Install the new PCV outlet hose onto barb.



133. Install the plain end of the 43"PCV outlet hose on the passenger (right) side of the engine.

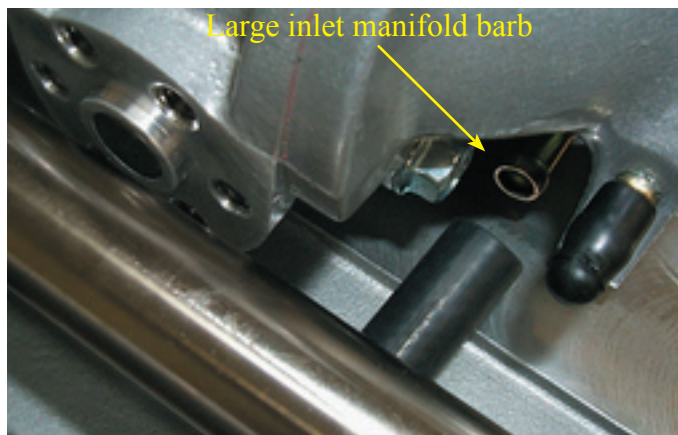

134. Insert the new check valve into the 11/32" brake hose supplied.



135. Install the new check valve and hose onto the brake vacuum booster.



136. On the driver (left) side of the engine connect the brake hose to the large barb on the inlet manifold. Route the brake hose along the side of the engine and behind the supercharger to the brake booster.

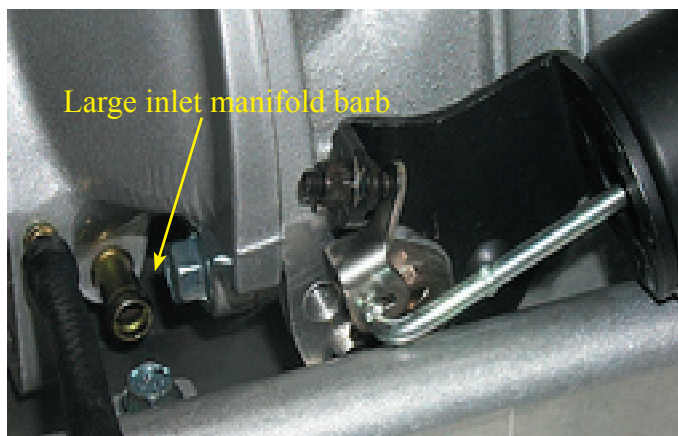

137. Locate the EVAP pipe removed earlier.



138. Using a sharp knife, carefully cut the plastic pipe so that the end fittings can be reused.



139. Here is the fittings removed from the pipe and the new supplied hose and clamps.



140. Secure the clamps by using a pair of side cutting pliers to crimp the loop of the clamp around the hose. Take care not to cut the loop but only tighten it.



141. Here is the new EVAP hose assembled and ready for installation.



142. Install the new EVAP hose onto the rear barb of the purge solenoid and into the firewall connector. Next connect one end of a 12” length of 3/8” hose to the front barb of the purge solenoid.

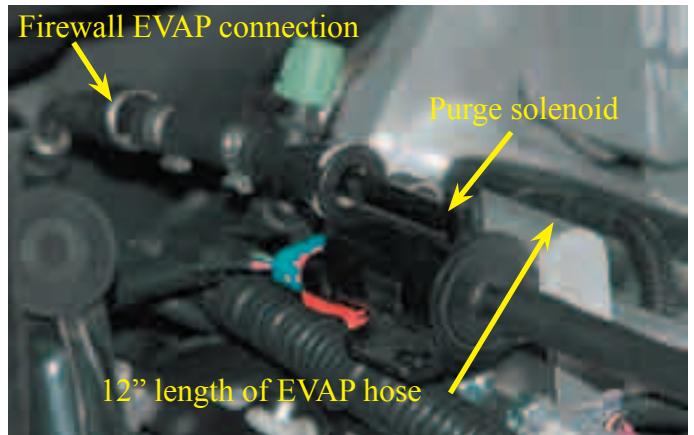

143. Install the fuel line extension into the firewall fuel line connector.



144. Connect the remaining end of the fuel line extension to the fuel manifold connector



145. Re-install the fuel line retaining clip.



146. Connect the remaining end of the EVAP hose from the purge solenoid to the small barb on the right side of the supercharger inlet manifold.

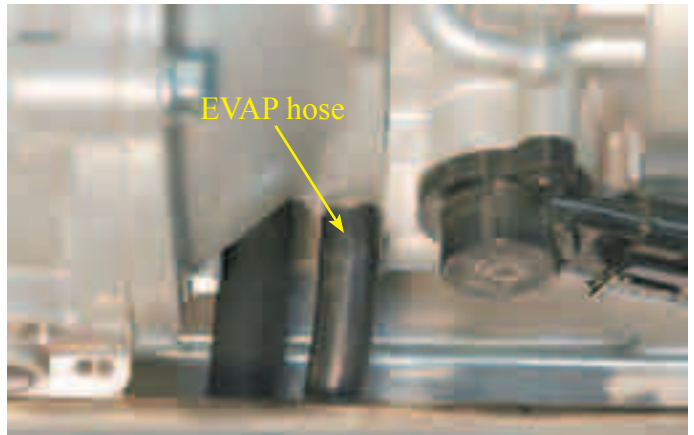

147. Install one end of a 24" length of the 1/4" coolant line onto the right side throttle body coolant barb. Secure the coolant line with a #4 clamp supplied.



148. Route the 24" coolant line along the front of the supercharger manifold and under the Mass Air Flow meter (MAF). Use the supplied 1/4" hose connector and another #4 clamp to connect the coolant line to the vehicles coolant vent line using the original clamp.

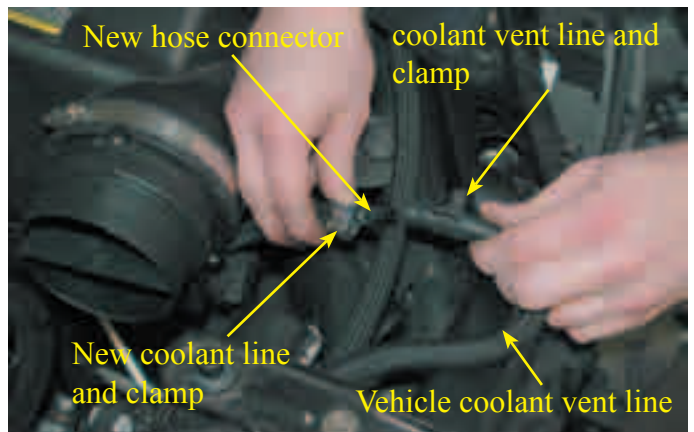

149. Install one end of the 20" length of 1/4" heater hose on the coolant vent pipe barb. Secure the hose with a #4 clamp supplied.

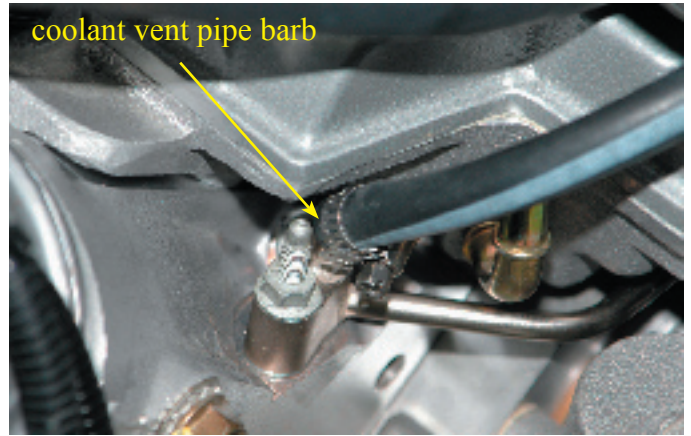

150. Connect the remaining end of the 20" coolant hose to the left side throttle body barb using a #4 clamp supplied..



151. Here is the new accessory drive belt routing diagram.

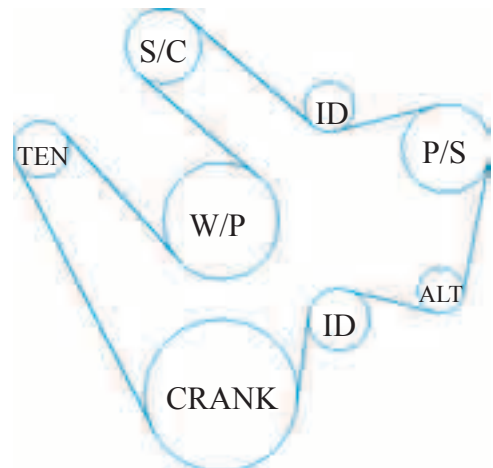

152. Using a long 15mm wrench to compress the tensioner, install the new belt using the diagram above.



153. Re-install the radiator into the vehicle. Re-install the radiator hoses, fan electrical connections and A/C line support tab. The radiator mask will be installed in a later step.



154. This is a diagram of the complete intercooler system plumbing. Note the routing of the hoses and their connections.

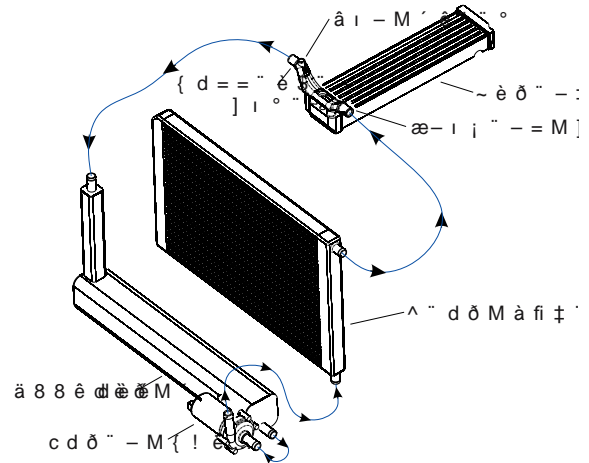

155. At the lower A/C condenser attachment points, remove the two bolts on each side with a 8mm socket wrench. At these two locations the new heat exchanger will mount.

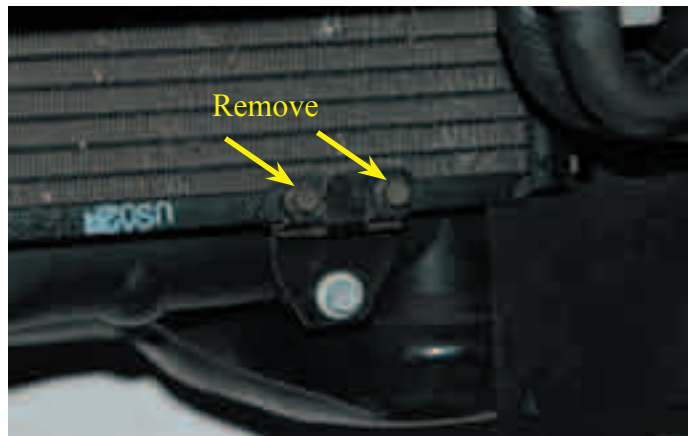

156. Carefully slide the new heat exchanger in position, up from the bottom, in front of the A/C condenser.



157. Bolt the heat exchanger into place using the supplied Allen bolts and a 4mm Allen socket wrench.



158. Remove the the lower right A/C condensor mounting bolt with a 10mm socket wrench. Install the two reservoir brackets using the A/C mounting bolt and a new supplied bolt in the center attachment point on the radiator tank.

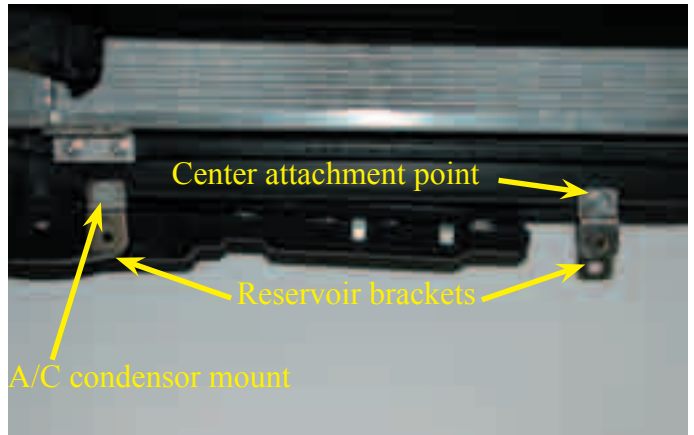

159. Here is the intercooler reservoir tank. Note the slotted rail on the front surface. There are two rails on the back as well.

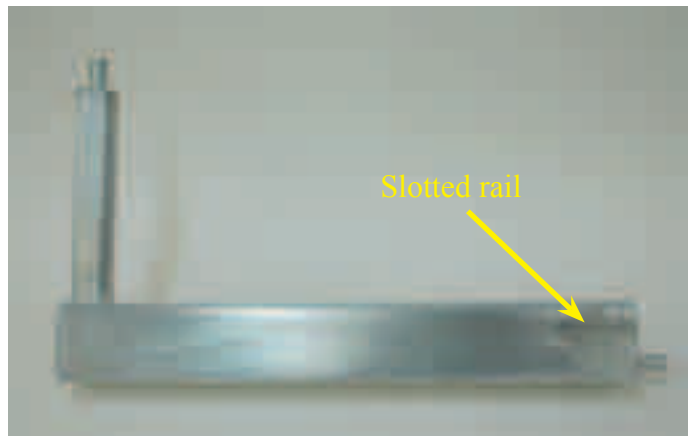

160. Here is the intercooler pump and mounting hardware. Note the round head bolts for mounting the pump.



161. Install two of the round head bolts into the slotted rail on the front of the reservoir as shown. Note that the square portion of the bolt shaft must be aligned with the sides of the channel.



162. Mount the intercooler pump to the reservoir in this position using the supplied Adel clamps, bolts and nuts. Tighten the nuts securely with a 10mm wrench.



163. Install the two remaining round head bolts into the rails on the back of the reservoir.



164. Install the reservoir and pump assembly onto the two brackets installed in step 158.



165. Secure the reservoir and pump assembly to the bracket using the supplied nuts. Tighten the nuts securely with a 12mm wrench.



166. Next to the left headlamp locate the air filter box boot. The boot will need to be removed to provide more air to the air filterbox and to allow passage of the heat exchanger lines.



167. To remove the boot, drill out the two mounting rivets at the front of the boot.



168. There are two additional retaining buttons securing the boot. Remove these buttons and the boot by prying them free with a large straight blade screwdriver.



169. Cut the “J” shaped hose as shown so it forms a “U” and a right angle “L” hose



170. Cut approximately 3” off the short leg of the large “L” hose supplied as shown.



171. Install one end of the 24” length of 3/4” hose to the left side intercooler manifold barb. Secure the hose with a #10 clamp supplied using a 8mm nut-driver.



172. Secure the remaining end of the 24” hose to the reservoir inlet barb with a #10 clamp.



173. Attach the “U” shaped hose to the pump inlet barb and the reservoir outlet barb using the #10 clamps supplied. Tighten the clamps securely with a 8mm nut driver.



174. Attach the “L” shaped hose to the pump outlet barb and the heat exchanger inlet barb using two #10 clamps supplied.



175. Route the large “L” hose through the area created by removing the air box boot. Attach the short leg of the large “L” hose to the outlet barb of the heat exchanger with a #10 clamp.



176. Connect the remaining leg of the large “L” hose to the left barb on the intercooler manifold and secure it with a #10 clamp. Tighten all hose clamps securely with a 8mm nutdriver except for the clamp on the right side intercooler manifold barb.



177. Here is the air tube assembly components. Note the two different lengths of hose and the raised “Rib” around one end of the tube. This end of the air tube will go towards the throttle body.



178. Assemble the air tube assembly by sliding the hoses all the way onto the air tube and then place the #60 clamps in position. Note that the shorter of the two hoses will go on the end of the tube with the raised “Rib”. Do not tighten the clamps at this time. Peel the paper backing from the rubber pad supplied and attach the pad to the underside of the air tube in the position shown.



179. Install the air tube assembly by pushing it against the MAF and then sliding the hose and clamps on to it.



180. Slide the hose and clamp onto the throttle body and then tighten all the hose clamps securely with a 1/4” nut driver.



181. Here is the intercooler pump harness and components.



182. Install the intercooler pump wiring harness at the Fuse/Relay center located at the front right corner of the engine compartment. Remove the Fuse/Relay center cover and using the legend printed inside, find the forward fuse location marked "SPARE" as shown.

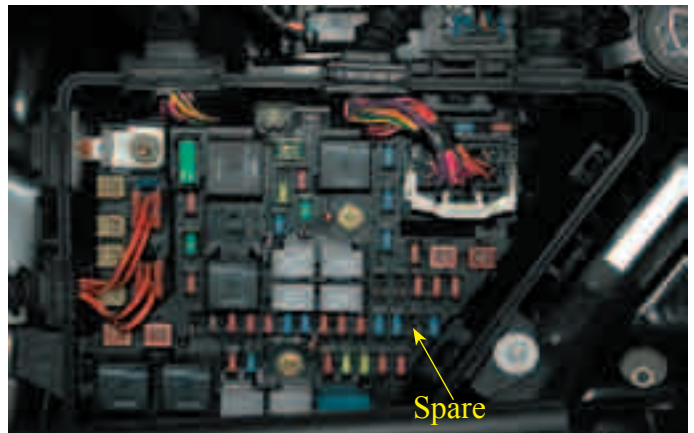

183. Place one leg of the supplied 15amp fuse through the Fuse-Tap as shown.

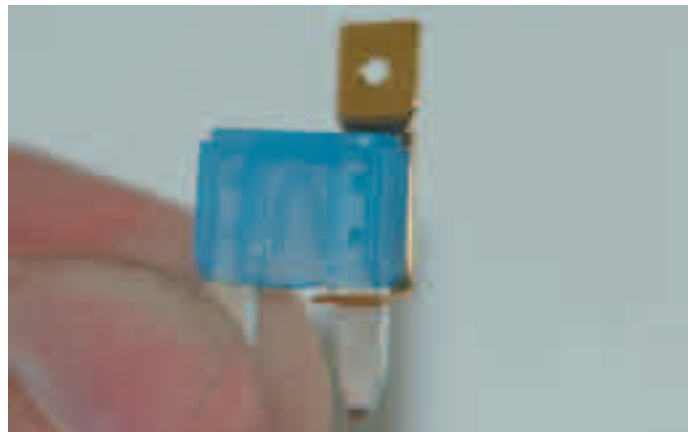

184. Install the new fuse and Fuse-Tap into the "Spare" location.



185. On the end of the yellow wire from the relay harness, strip the insulation back 1/4" and crimp on the female spade terminal. Connect the female spade terminal to the male spade of the Fuse-Tap.



186. Connect the Black ground (-) wire with the ring terminal to the forward bolt that secure the fuse/ Relay center to the chassis. Remove the bolt with a 10mm wrench and place the ring terminal on the bolt. Re-install the bolt and tighten it securely.



187. Connect the Red positive (+) wire with the ring terminal to the main power connection on the Fuse/Relay Center. Remove the nut with a 13mm wrench and place the ring terminal on the stud. Re-install the nut and tighten it securely.



188. Place the relay into the rear corner of the Fuse/Relay center. Using a sharp knife, cut away at the top of the harness boot to allow the ground and pump wire from the relay to pass from the inside to the engine compartment. Replace the cover to the Fuse/Relay center.

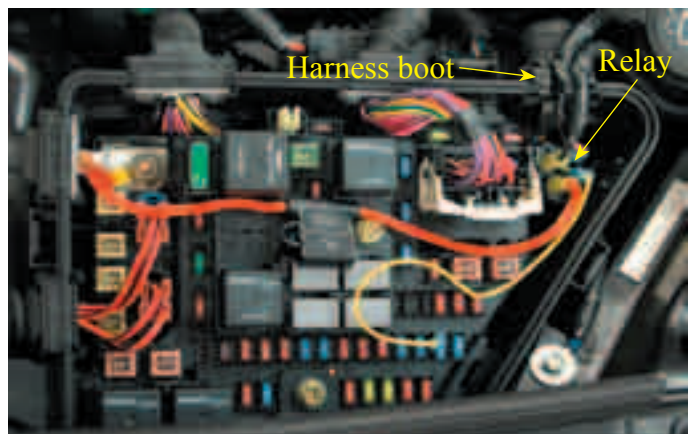

189. Connect the Pump connector to the end of the intercooler pump.

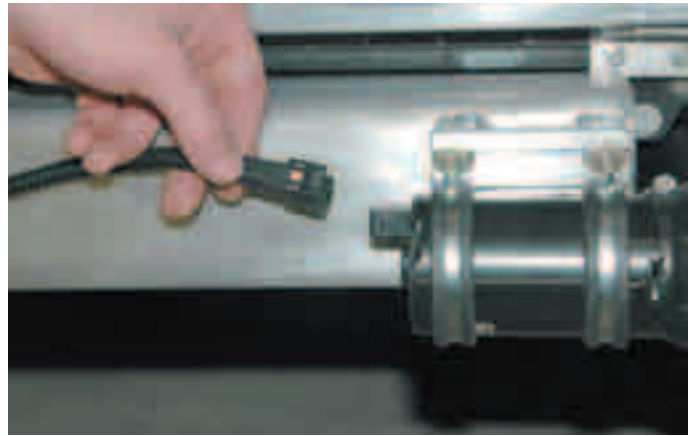

190. Re-install the front fascia by first re-connection the four electrical connectors on the inside of the fascia.

Note the heads of the lock bolts in the top edge of the fascia, these must stand proud in order to engage the “keyhole” slots in the bottom edge of the fenders.

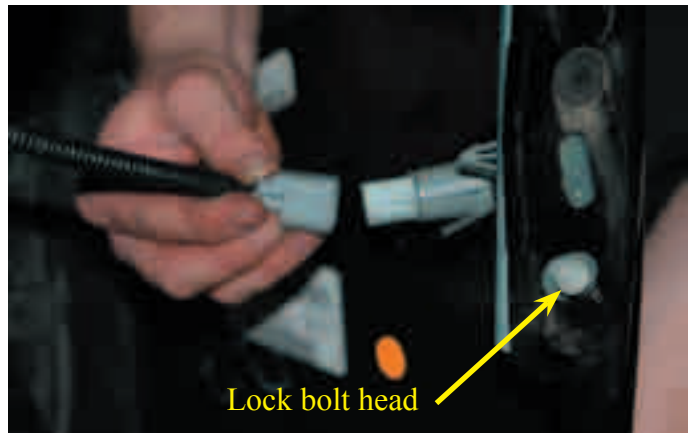

191. Set the front fascia in position on the vehicle.



192. Line up the lock bolt heads with the “keyhole” slots in the bottom edge of the fender. Push up on the fascia and then back to re-attach the fascia to the fenders. Rotate the steering wheel to move the road wheels inward on each side to gain access to the lock bolt nuts through the wheel well. Take care to ensure the fascia lines up correctly and tighten the lock bolt nuts securely.

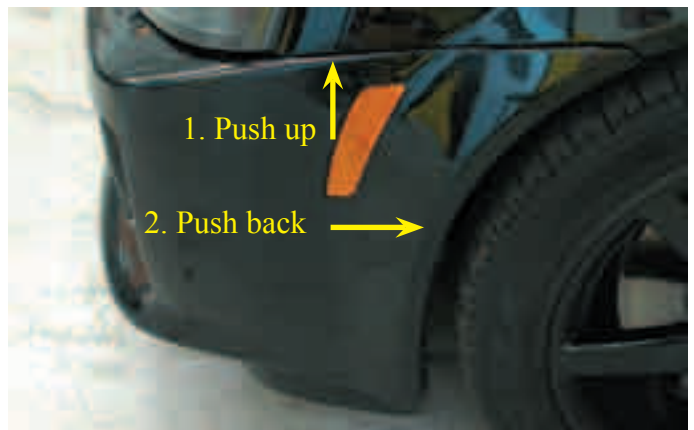

193. Re-install all the push reivets into their original locations in the fascia and wheel wells.



194. Re-install the lower front splash panel with its push rivets.



195. Snap the radiator mask into place and secure it with the push rivets.



196. Here are the fuel pump booster components and mounting hardware.



194. Remove the “D” shaped trunk floor cover by unscrewing the retainer located in the center.

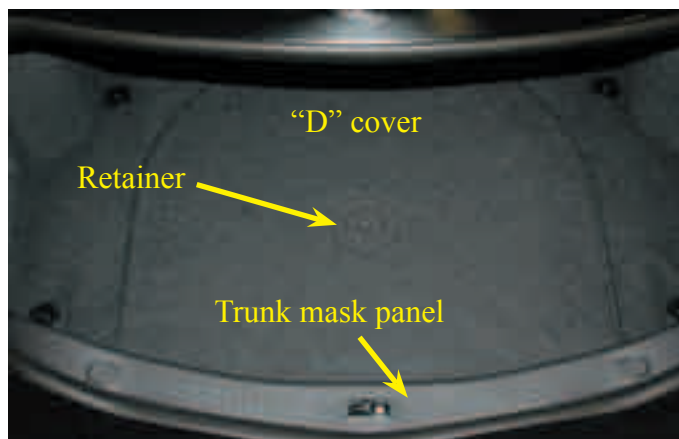

195. Remove the four retainer buttons that secure the trunk mask panel to the rear of the trunk by unscrewing them. There is one button on the floor and one on the wall on each side

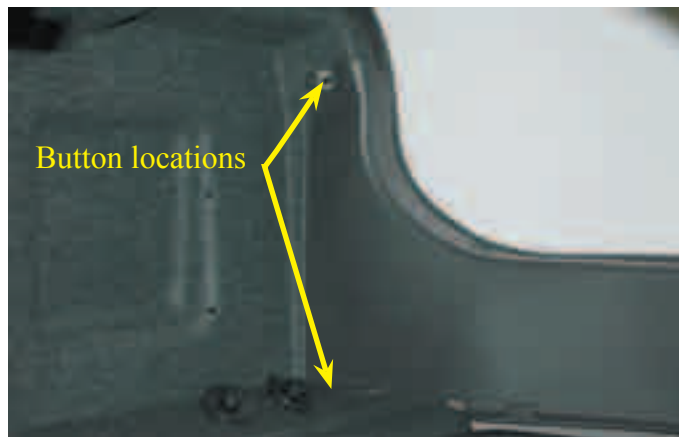

199. Remove the trunk mask panel from the trunk compartment.



200. Pull the right interior panel out and push it forward to gain access behind it.



201. The fuel pump booster will mount on the trunk floor using the supplied Velcro strips supplied. Peel the backing off the two Velcro strips and apply it to the bottom of the module and to the trunk floor near the two studs on the floor.



202. Here is the module mounted in location. The chassis electrical ground connection on the wall above the module. This is where the module ground connection will be connected.

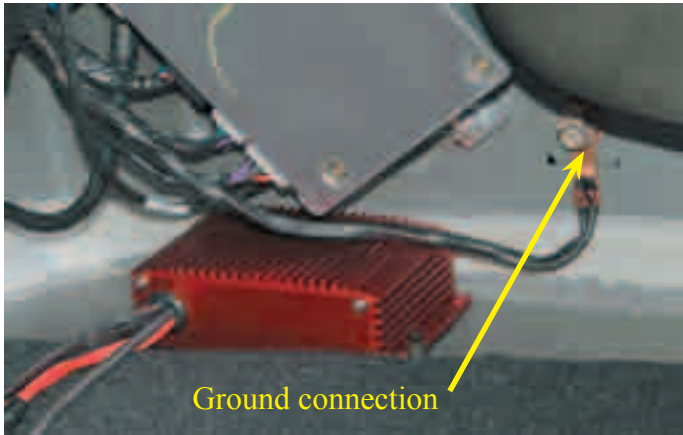

203. From the module wires locate the large black (ground) wire and cut it to length so that it will reach the ground connection on the trunk wall. Strip the wire insulation back about a 1/4" and crimp the large ring connector on as shown.



204. Remove the ground connection bolt with a 10mm socket wrench and install the module black ground wire on it. Re-install the bolt and tighten securely.

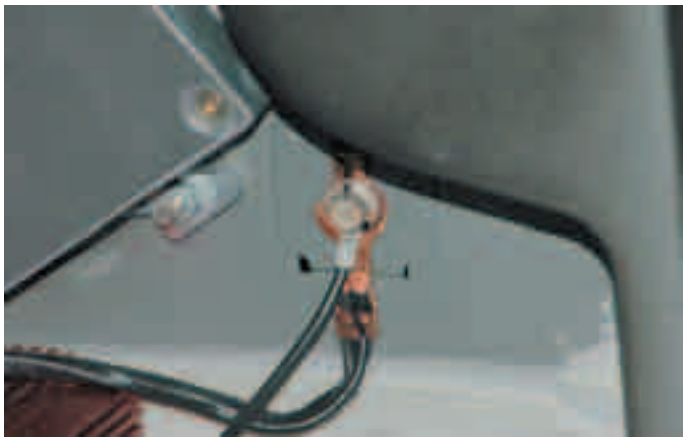

205. Locate the large branch of the wiring harness running down the wheel well. Carefully cut the tape and locate the large **GREY WIRE**. Pull the large grey wire out of the bundle, this is where the booster connections will be made.

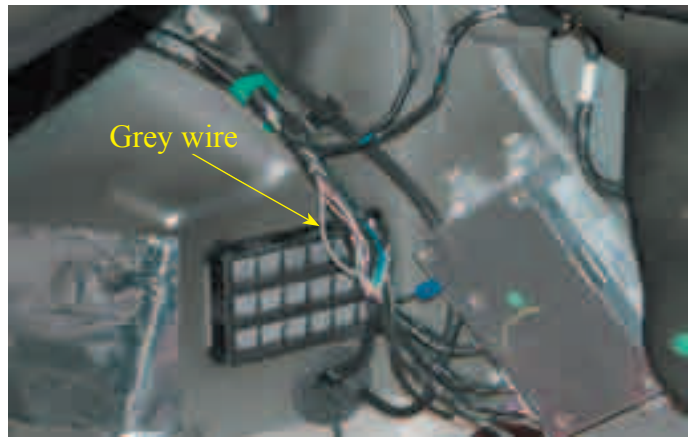

206. Cut the large grey wire and strip the insulation back from the two ends about 1/4”.



207. Using the crimp connectors supplied, connect the large **RED wire with the in-line fuse to the Upper grey wire**. Connect the remaining large **Red wire to the lower grey wire** that runs to the fuel pump.

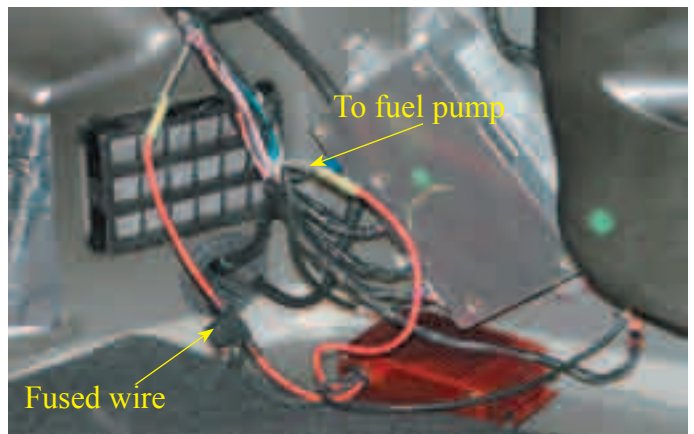

208. Push all the cable containing the small black and red wires through the grommet and into the wheel well. the cable will follow the factory wire harness under the vehicle and forward. Replace the trunk interior, “D” and mask panels with their retainers and buttons.

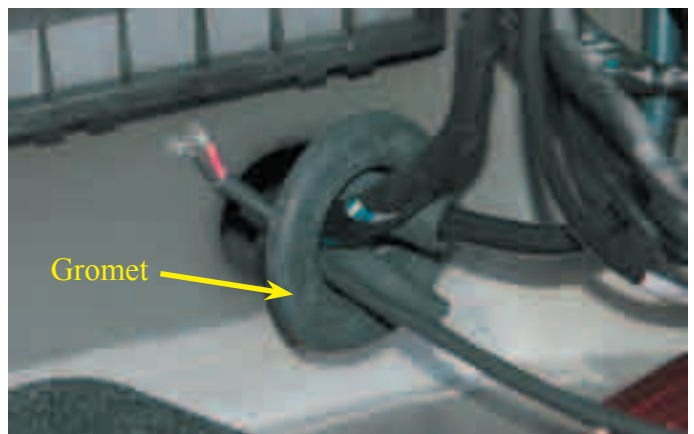

209. The cable will follow the factory harness on the bottom of the vehicle over the top of the differential and then to the passenger side where it will follow the brake and fuel lines to the engine compartment.

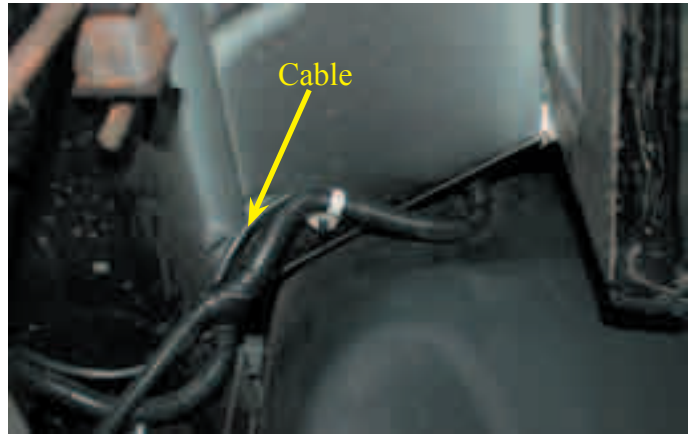

210. Route the cable forward along the brake and fuel lines to the firewall on the drivers side of the engine compartment. Take care to keep the cable away from any rotating or hot exhaust parts. Secure the cable with the cable tie straps supplied.

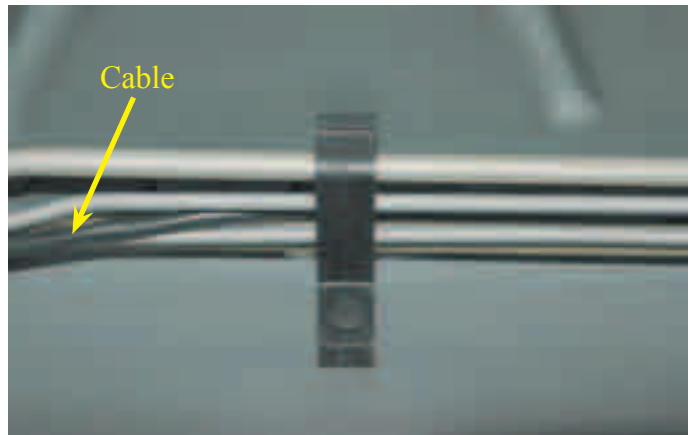

211. Route the cable up the drivers side firewall and to about the shock tower. Cut the cable and strip the wire insulation back about a 1/4" on both red and black wires. Crimp the female spade connectors on the end of the wires as shown.



212. At the left rear of the supercharger manifold, locate the vacuum nipple there.



213. Using the pressure switch and the small vacuum hose supplied attach the pressure switch to the vacuum nipple on the manifold. Route the switch forward to lay beside the wiring harness and secure it there with the cable ties supplied. Connect the red and black wire connectors from the fuel pump booster cable to either pressure switch spade connection.

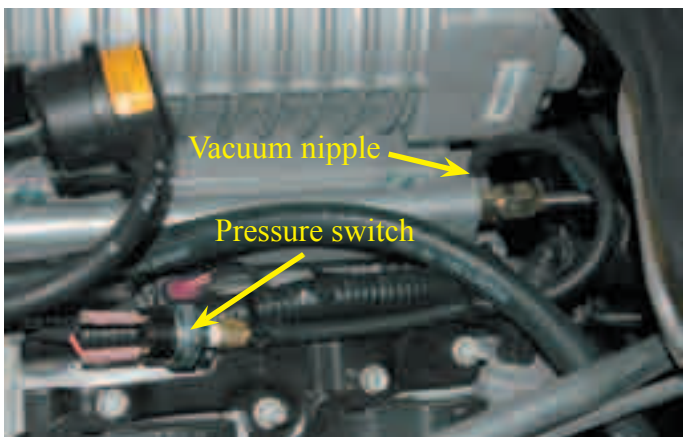

214. Remove the hose from the right side intercooler manifold barb and inset a large funnel into it. Fill the intercooler system with a 50-50 mixture of GM approved coolant and distilled/de-ionized water. The complete system will hold approximately 2 gallons (8 liters).



215. Reconnect the negative battery connection with a 8mm wrench.



216. Attach a short length of hose to the right intercooler manifold barb temporarily and route it to the mouth of the funnel as shown. Switch the ignition on but **DO NOT START THE ENGINE!** Allow the intercooler pump to circulate the coolant mixture through the system for a minimum period of at least 10 minutes. This will purge the intercooler system of any air bubbles and ensure maximum performance. After 10 minutes switch off the ignition and remove the temporary hose from the intercooler manifold. Reattach the intercooler hose to the manifold and tighten the clamp securely.



217. Start the vehicle for 5 seconds and shut off, once again check for fuel leaks and supercharger belt alignment.

Test drive vehicle for the first few miles under normal driving conditions, listen for any noises, vibrations, engine missfire or anything that does not seem normal. The supercharger does have a slight whining noise under boost conditions, which is normal.



218. After the initial test drive gradually work the vehicle to wide open throttle runs, listen for any engine detonation (Pinging). If engine detonation is present let up on the throttle immediately. Most detonation is caused by low octane gasoline still in the tank. With the ignition on, but the engine not running, use a straight blade screwdriver to open the air bleed valve on the top of the intercooler water manifold. A small amount of air will escape. Close the valve when fluid comes out. Do this again after 500 miles.



220. In the event that the vehicle needs to be returned to its original calibration, follow the directions as described in the previous steps. The handheld unit will prompt you that you have already modified the vehicle's computer. Select YES to return you vehicle's computer back to the stock calibration. Wait for the handheld to finish, then disconnect cable plug as directed.



If you have questions about your vehicles performance, please check with your installation facility or call Magna Charger at (805)642-8833, Monday through Friday, 8am to 5pm.



Please enjoy your “Magna Charged” performance responsibly.